

MICROPROCESSOR BASED SOLAR TRACKING SYSTEM USING STEPPER MOTOR

Jyotirmay Gadewadikar

B. E. Final Year (Electronics), S.G.S. Institute of Tech. & Science, Indore

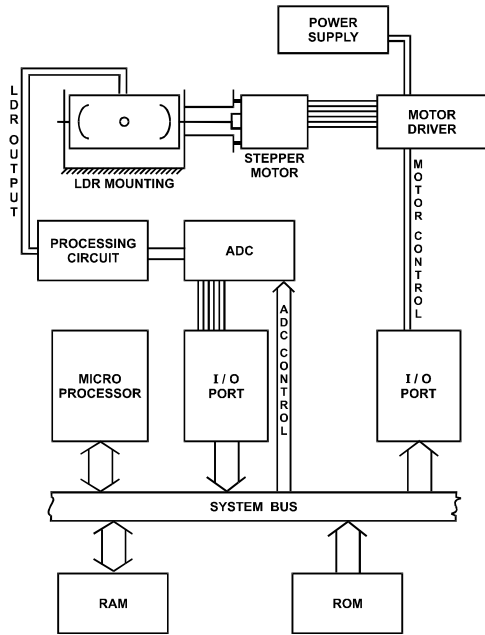

BLOCK DIAGRAM OF THE PROJECT

This project uses a stepper motor to control the position of solar energy collectors, using Intel 8085 μ p. The software includes the positioning of collectors through stepper motor & data acquisition and processing in Microprocessor.

OPTICAL SENSING AND PROCESSING :

LDR (Light Dependent Resistance) is used as a sensor for generating an electric signal proportional to intensity of light falling on it. LDR is mounted at the focus of reflector which is directly mounted on solar energy collectors.

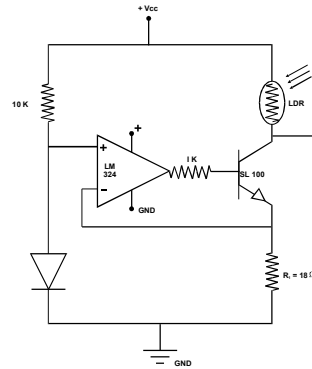

L.D.R. SIGNAL PROCESSING CIRCUIT

STEPPER MOTOR AND ITS DRIVING CIRCUIT

The stepper motor requires that its stator windings should be energized in a programmed sequence to cause the motor to run in a given direction and with a required speed.

Hardware design can be categorized into two parts

(a) Logic sequence generating circuit

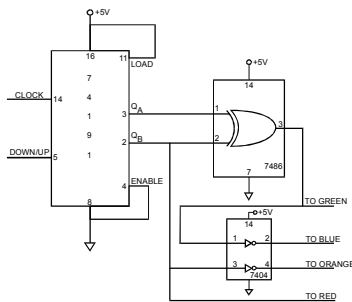

LOGIC SEQUENCER CIRCUIT

(b) Driving Circuitry

DRIVER CIRCUIT

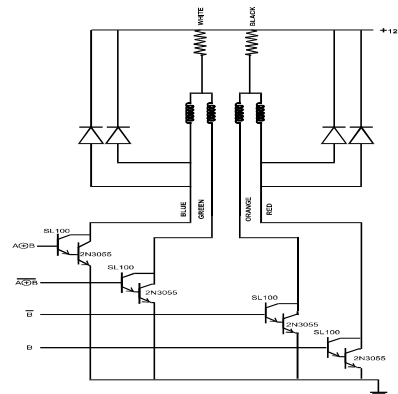

Interfacing With Microprocessor

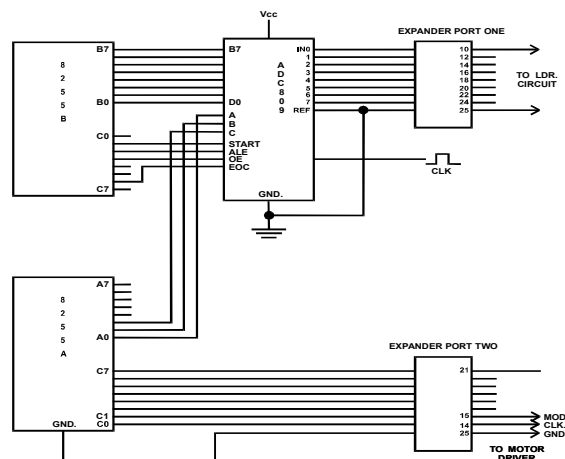

INTERFACING WITH MICROPROCESSOR

THE TRACKING SOFTWARE

MAIN PROGRAM

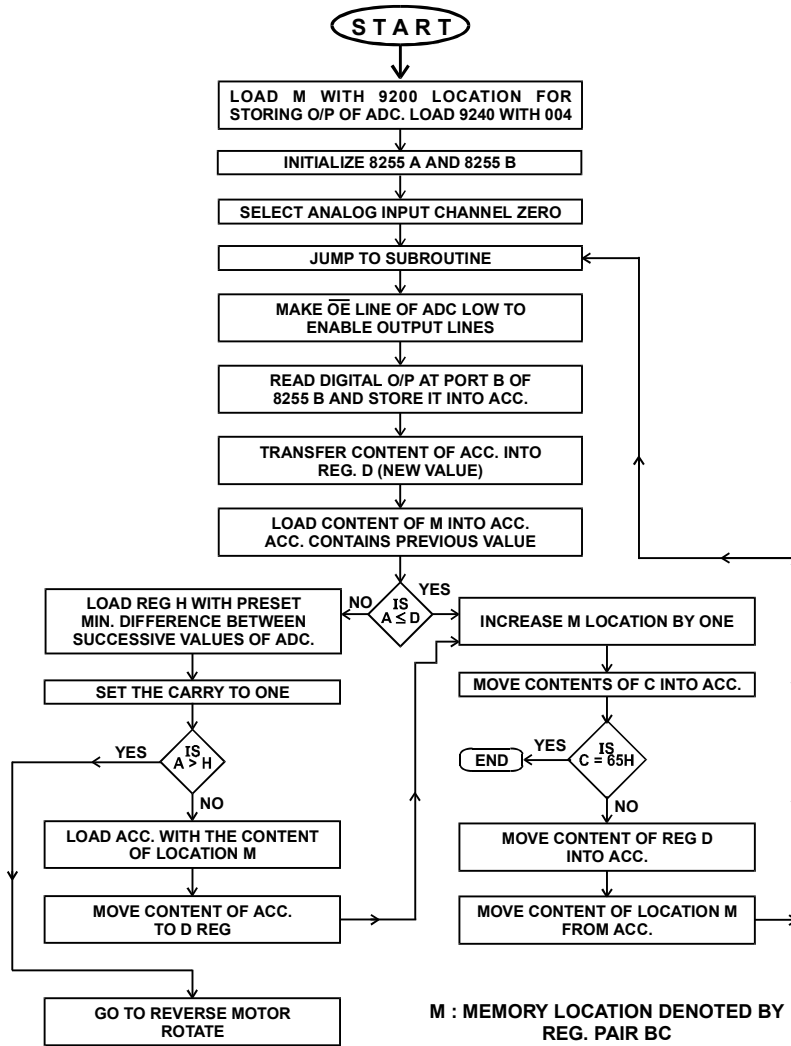

SUBROUTINE

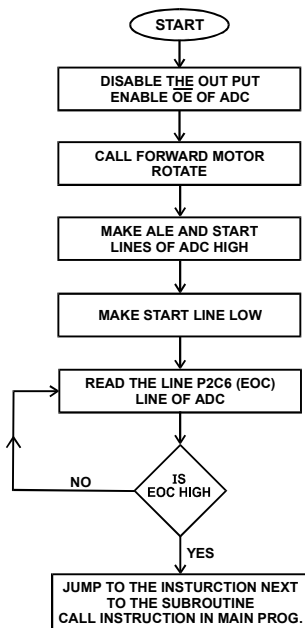

FORWARD MOTOR ROTATE

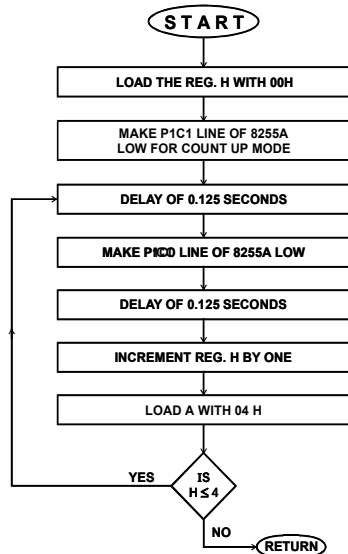

REVERSE MOTOR ROTATE

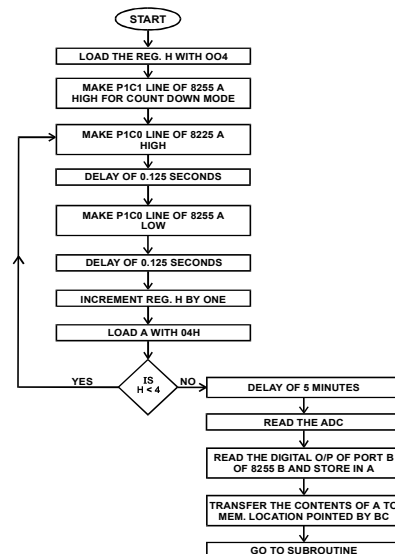

MICROPROCESSOR BASED FIBRE OPTIC PRESSURE SENSOR

Jyotirmay Gadewadikar, Department of Electronics, Shri Vaishnav Institute of Technology & Science, Indore.

The system works on the principle of micro bending of optical fibres. Low cost, constructional simplicity, versatility and microcomputer compatibility are some of the important features of the proposed device. The design of the instrument involves a fibre optic sensor, hardware and software parts.

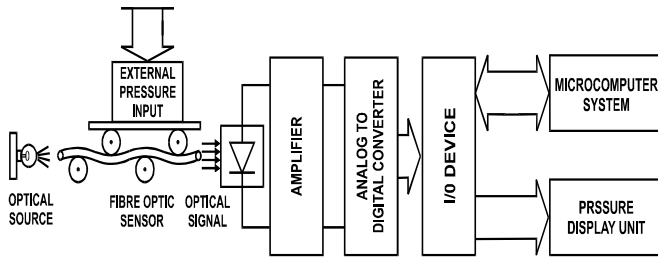

SCHEMATIC OF SENSOR SETUP

Principal of Operation:

Loss of optical signal inside the fibre when pressure is applied on the surface of a monomode optical fibre is known as microbending losses.

Microbending loss for monomode fibres is related by expression.

$$\alpha \sim \omega_0^{2+4p}$$

$p = 0, 1, 2, \dots, n$, n being a positive integer.

ω_0 = Spot Size, α = Attenuation coefficient.

Hardware design details:

Sensor : The sensor used for pressure measurement is based on microbending principle. The sensor has 2 ft. long fiber of 50 micrometer core diameter. The Fibre is placed between two corrugated surfaces, out of which the upper one is movable and the lower is fixed. Optical power is taken from a 6.0 V drywell torch bulb and is given to the core of the fibre. On application of continuous physical pressure varying from .02 Kg/cm² to 20 Kg/cm² on the upper surface, the fibre undergoes a proportional microbending resulting into losses and attenuation of the optical signal. A pin photodiode(SI 100S) acts as photo detector at the receiving end of the fibre.

Signal Conditioner : Signal from photo detector is amplified through a DC Amplifier using OPAMP 741. The analog amplified output needs to be converted to Digital Signal before it is applied to a Microprocessor which is done through ADC 0809.

Microprocessor Interfacing Circuit: ADC is interfaced with an 8 bit Intel 8085 μ P via a programmable peripheral interface(Intel IC 8255). Clock for ADC is taken from μ P after manipulation using a monolithic decade counter (IC 7490).

Pressure Indication Circuit : ICMAN74A, a common Cathode display Chip is used for automatic display. The circuit includes a LED decoder/driver IC 74LS48P to interface the 7 Segment display with the I/O IC 8255.

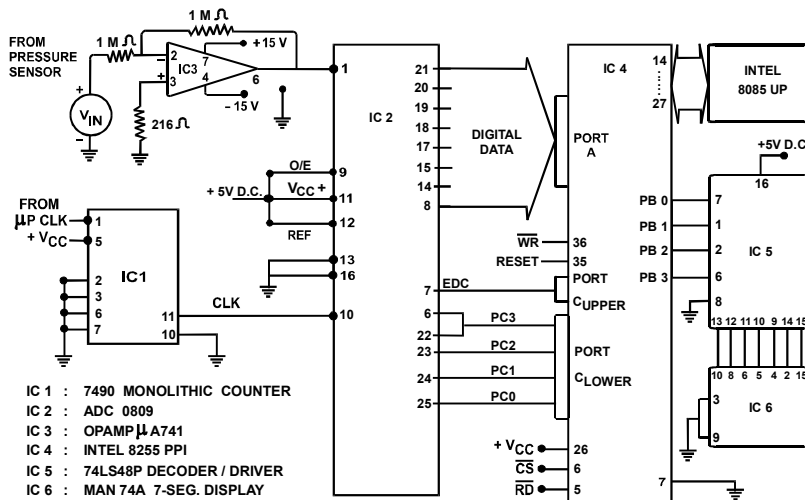

ELECTRONIC CIRCUIT

numbers and are stored into a look up table.

5. The data received from the online sensor is compared with prestored look up table.

6. Display subroutine is called.

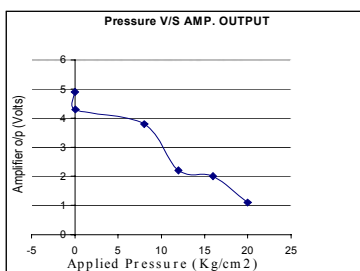

RESULTS & CONCLUSIONS:

The developed instrument was subjected to different magnitude of applied pressure, it is observed that output of amplifier decreases almost linearly in accordance with applied pressure, the system can be used for measuring static as well as dynamic loads.

A. I. - A REALITY

JYOTIRMAY GADEWADIKAR

B.E. IV Year Electronics
S. G. S. Institute of Technology & Science, Indore

ABSTRACT

The Computers have invaded into every walk of life. Almost in every other situation computers are being used as an indispensable tool. The problem / processes which are complex in nature, involve number of inter-dependent variables & non-linearities which can be solved to some extent with the help of Micro-Processors based systems/controllers. However, they are insufficient to the extent that they fail to generate any control signal in situations which are not defined or unknown under such circumstances, A.I. seems to resolve the problems in a much effective way. Today A.I. has been used in disciplines like Military, Space, Medicine and Process Industry where conventional methods do not give sufficient precision & are therefore not suitable.

This Paper is concerned with the application of Artificial Intelligence in such fields where A.I. is realized in a much effective way.

COLD ROLLING MILL AUTOMATION

**L. P. Halway (Dept. Manager), Jyotirmay Gadewadikar(Sr. Officer)
C R M Complex, Tata Steel**

ABSTRACT

Indian Steel industry is employing new information technology solutions as a part of facility revamping programme to meet the challenges of the twenty-first century. The information technology reaches obsolescence much before the manufacturing technology it supports. Hence it is extremely important to employ IT architecture which would protect investment, allow-incremental development and scalability, and ensure lower cost of ownership. This presentation makes an attempt to primarily address issues related to computerization and automation and explain an IT architecture classifying into Four Levels of Automation that can sustain the IT requirement for a long period.

Level 4	Sales & Distribution, manufacturing Planning, Financials, Plant maintenance, costing Transportation
Level 3	Production Planning & Control, Quality Control, Energy management, Conditioning Monitoring, Process MIS
Level 2	Material Tracking, Process Optimization, SCADA.
Level 1	Direct control Through PLC, RTU etc.

Tata Steel is in the process of implementation of a complex IT and automatic solution for its new CRM at Jamshedpur. The new plant is integrated with its hot strip mill. So is its new information system, called CRMIS. There are many design trade-offs to

- (i) Use the existing IT set-up and
- (ii) Implement best-of-breed new technology solutions for the new plant.

This presentation addresses the information architecture in the context of a steel plant, particularly, CRM. Implementation of the manufacturing applications and integration of the plant applications along with the Supply chain and Customer relationship management solutions are the biggest challenges to the Information System departments of all steel plants at present.

CPU Design.

Abstract: Control, ALU and External Memory Block description, performance verification using VHDL and RTL synthesis tools. Control block handles the state machine for the memory interface and ALU functions.

A CPU (cpu.vhd) consists of 2 sub-blocks:

1. CONTROL (control.vhd)
2. ARITHMETIC (alu.vhd)

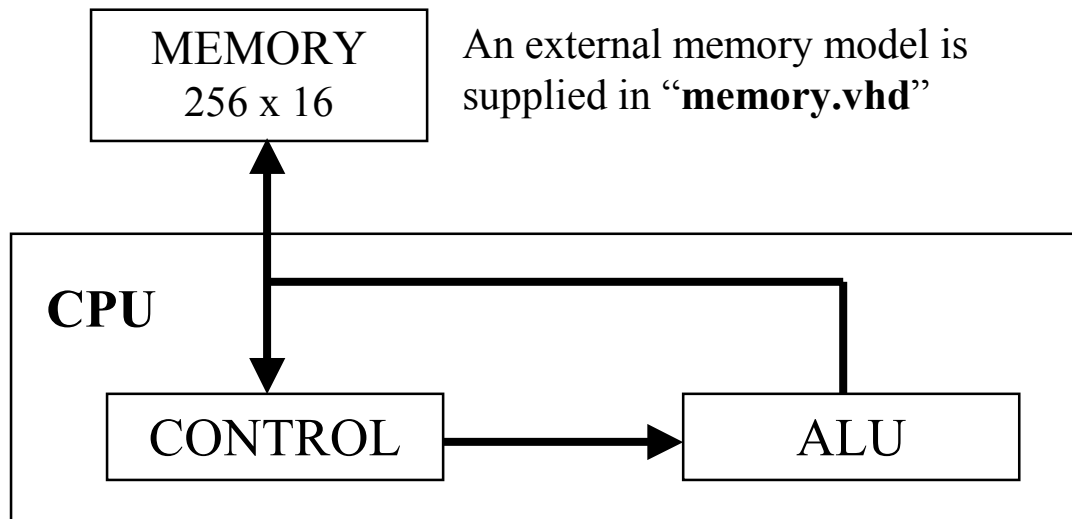

The CPU performs the following operations: Idle, Add, Subtract, AND, NOT, Load memory to Register, Store register to memory, and Jump. (See next page.)

The ALU contains an 8 word by 16 bit register file and handles the arithmetic and logical operations. The selection of which register words the operation is performed on comes from the instruction source1, source2, and destination fields. For example if an addition operation with source1=0 and source2=5 and the destination=1, then the register words 0 and 5 are added together and the result placed in register 1.

The control block handles the state machine for the memory interface and ALU functions. The control will handle all memory read, write, and chip select control outputs.

The Load command will take a word from external memory, addressed by a field in the instruction word, and store it in a word of the 8x16 register block, indexed by the destination register. These Load operations allow the internal registers to be filled before ALU operations are performed.

The instructions are loaded from the external memory. The control block keeps track of the external memory instruction address. The Store instruction will take a word from the internal register block and store it in external memory. A Jump instruction will change the memory instruction address.

Instruction format INSTR(15 downto 0):

```
15 14 13 12 11 10 09 08 07 06 05 04 03 02 01 00
<- OP -> <-DEST-> <-SRC1-> <-SRC2->
<--- MEM ADDRESS ----->
```

OP = INSTR(15 downto 13) :

```
000 => IDLE -- ALU does nothing, control gets next Instr.
001 => ADD -- Reg (DEST) <= Reg (SRC1) + Reg (SRC2)
010 => SUB -- Reg (DEST) <= Reg (SRC1) - Reg (SRC2)
011 => AND -- Reg (DEST) <= Reg (SRC1) AND Reg (SRC2)
100 => NOT -- Reg (DEST) <= NOT Reg (SRC1)
101 => LD -- Reg (DEST) <= MEM (INSTR (7 downto 0))
110 => STO -- MEM (INSTR (7 downto 0) <= Reg (DEST) ; 111 => JMP -- InstrReg <=
INSTR (7 downto 0)
```

CPU Design

